

# 150mm AIR HAMMER

## Specifications

Chisel Shank (Round)..... 10.2mm  
 Bore Diameter (ID)..... 19.05mm  
 Blow Per Minute..... 4,500BPM  
 Stroke..... 43mm  
 Average Air Consumption..... 4CFM@90PSI  
 Length..... 150mm  
 Air Inlet..... 1/4"  
 Weight..... 1.12kg

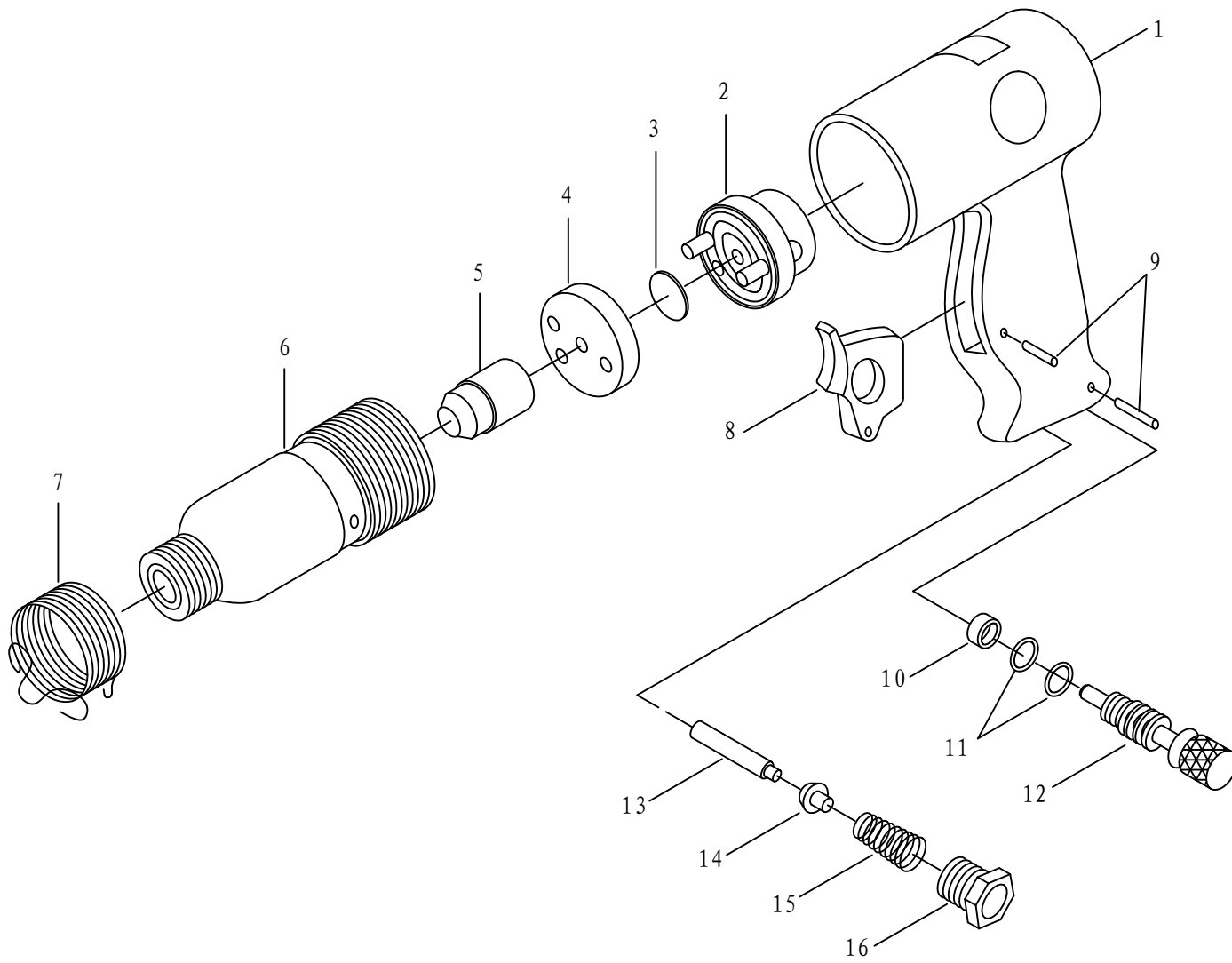

Ref.	Part#	Description	Q'TY
1	WFH-1040-01	Housing	1
2	WFH-1040-02	Sealing Valve	1
3	WFH-1040-03	Valve Plate	1
4	WFH-1040-04	Sealing Valve's Cover	1
5	WFH-1040-05	Piston	1
6	WFH-1040-06	Cylinder	1
7	WFH-1040-07	Spring	1
8	WFH-1040-08	Trigger	1

Ref.	Part#	Description	Q'TY
9	GB/T879.2-2000 3*16	Straight Pin	2
10	WFH-1040-09	Throttle Valve	1
11	O RING 8*1.9	O-Ring	2
12	WFH-1040-10	Adjusting Valve Pole	1
13	WFH-1040-11	Pin	1
14	WFH-1040-12	Gas Admittance Valve	1
15	WFH-1040-13	Taper Spring	1
16	WFR-1060-02	Air Inlet Connector	1